

---

# Table of Contents

## F01 Powertrain

<b>Subject</b>	<b>Page</b>
<b>Introduction</b> .....	<b>5</b>
The New Flagship .....	5
Drive Train Variants .....	6
Modifications as compared to the predecessor .....	6
<b>N63B44O0 Engine</b> .....	<b>8</b>
Vehicle-specific Modifications .....	9
Technical Data .....	9
Air Intake and Exhaust System .....	10
Intake Air Duct .....	10
Exhaust System .....	11
Cooling System .....	12
Engine Cooling .....	14
Charge Air Cooling .....	16
Engine Electrical System .....	17
Engine Control Unit .....	17
System Overview .....	18
<b>Fuel Supply System</b> .....	<b>20</b>
Fuel Supply System for the N63 Engine .....	22
System Overview .....	22
Fuel tank breather system and functions .....	26
Non-return Flap .....	28
Filler Breather Valve .....	28
Service breather valve with over fueling protection .....	29
Service breather valve without over fueling protection .....	30
Fuel Trap .....	31
Fuel Pump .....	32
Pressure Limiting Valve .....	32
Fuel Supply and Control Schematic Overview .....	33
<b>Automatic Transmission</b> .....	<b>34</b>
Technical Data .....	35
Transmission Control Schematic Overview .....	36
Gear Selector Switch .....	37
Emergency Release .....	37

---

<b>Subject</b>	<b>Page</b>
<b>Rear Axle Differential</b> .....	<b>.38</b>
Driveshafts and Axles Shafts .....	.38
Driveshaft .....	.39
Axle Shafts .....	.39

**BLANK  
PAGE**

---

# Powertrain

**Model: F01/F02**

**Production: From Start of Production**

# OBJECTIVES

After completion of this module you will be able to:

- Identify components related to the F01 powertrain
- Understand changes to the N63 engine
- Understand transmission related changes on the F01

# Introduction

## The New Flagship

As ever, developing a new 7 Series is a special challenge because this vehicle represents the pinnacle of technical achievement and, in this class, the demands placed on a wide variety of qualities are particularly high. During this development, we were faced with having to outdo not only the competition but also an excellent predecessor.



The drive train was particularly challenging in this respect. Here, superior dynamics meet ultra-smooth performance. Increasingly, however, fuel economy is also playing an ever more important role. And this is exactly where the “Efficient Dynamics” development strategy comes in. It combines improved driving performance with reduced fuel consumption.

The F01/F02 sets new standards in all of these areas. “Efficient Dynamics” is a strategy that aims not to find a compromise, but to achieve the best of all worlds.

---

## Drive Train Variants

At the time of market launch, the models of the 7 Series will be available with the following drive train variants:

<b>F01/F02</b>	<b>750i/750Li</b>
Engine	N63B4400
Power output [kW/bhp]	300/400
Torque [Nm]	600
Exhaust emission standard	ULEV II
Gearbox	GA6HP26TU
Rear axle differential	Rear diff 225AL
Final drive ratio	3.462:1

### Modifications as compared to the predecessor

This document describes the modifications to the F01 drive train by comparison with its predecessor, the E65. New or modified systems and components are also explained.

The following table shows an overview of the changes/modifications relative to the E65. Their descriptions are distinguished by various categories:

- New development denotes a new technology that has never before been used at BMW.
- Change denotes a component that was specifically developed for the F01 engine but does not represent a technological innovation.
- Carry-over denotes a component already fitted in other BMW models

Component	New development	Change	Carry-over	Remarks
N63B44O0 engine			●	The N63 engine fitted to the E71 has now been carried over to the F01/F02. Only the intake air duct and the exhaust system are vehicle-specific, and the engine management is now connected to the FlexRay.
Fuel preparation	●			Fuel preparation has been further improved in the area of the breather system. At the same time, the security against escaping fuel or fuel vapors has been further increased.
Automatic transmission			●	The 6HPTU has been carried over from the E70. On the F01/F02, too, the transmission is now controlled using the gear selector switch also adopted from the E70.
Rear axle differential	●			The F01/F02 are equipped with new final drives. It is the first time that BMW has fitted rear differentials having an aluminum casing. They have also been optimized for low-friction operation.
Shafts		●		The propeller shaft has a push-fit connection to the rear axle differential as it does on the E70. For the first time, this connection has a flexible coupling. The drive shafts have a push-fit connection at both the differential end and at the wheel end. Both hollow and solid shafts are used.

## N63B4400 Engine

The 750i/Li also underwent a series of downsizing measures, although its increased power output is more immediately obvious than its reduced engine capacity.

The N63 engine makes use of the same technology for mixture preparation as the N54 engine, i.e. twin-turbochargers and High Precision Injection (HPI) operating permanently in homogenous mode.

The engine is relatively new to the market. It was introduced in May 2008 under the hood of the X6 xDrive50i, where it would deliver breathtaking performance.

### N63 engine





The N63 engine's most extraordinary feature has to be the location of its turbochargers - in the engine valley - hence the arrangement of the cylinder heads where the hot exhaust side is turned inwards. It is the first automobile gasoline engine in the world to have such an arrangement.

By positioning the turbochargers and the catalytic converters in the engine valley, it was possible to make optimum use of this space to bring essential turbocharging components together.

Consequently, only the relatively small intake manifolds (due to turbocharging) are present on the outside of the engine. This enables the engine to be integrated into a range of different vehicle and drive train concepts without any major modifications being required.

Particular challenges are faced, however, in the cooling system and charge-air line.

## Vehicle-specific Modifications

The N63 is a relatively new engine. For use in the F01/F02, hardly any modifications were required.

The following components were adapted:

- Oil sump
- Intake air duct
- Exhaust system
- Cooling system
- Engine electrical system.

## Technical Data

Model Vehicle	750i/Li E65/E66	750i/Li F01/F02
Engine	N62B4801	N63B4400
Engine type	V8	V8
Displacement [cm <sup>3</sup> ]	4799	4395
Stroke/bore [mm]	88.3/93	88.3/89
Output at engine speed [kW (bhp)] [rpm]	270 (367) 6300	300 (407) 5500
Torque at engine speed [Nm] [rpm]	490 3400	600 1750
Compression ratio [ ]	10.5	10.0
Fuel specification [RON]	98	98
Fuel [RON]	91 - 98	91 - 98
Digital motor electronics	ME9.2.2	MSD85
Exhaust emission standard	ULEV II	ULEV II
Acceleration 0-100 km/h (0-62mph) [s]	5.9/6.0	5.2/5.3

## Air Intake and Exhaust System

### Intake Air Duct

The intake air duct in the F01/F02 differs negligibly from that of the E71. In the interests of space-saving, the unfiltered air duct has been relocated. Now air is taken in from the side of the BMW kidney grille. Also evident is the one resonator on each of the two unfiltered air pipes. The upper section of the intake silencer has also undergone a vehicle-specific modification.



Index	Explanation	Index	Explanation
1	Unfiltered air intake	4	Intake silencer
2	Unfiltered air resonator	5	Hot-film air mass meter
3	Unfiltered air pipe	6	Purified air pipe

## Exhaust System

When designing the dual outlet exhaust system in the underbody area, our development engineers focused on achieving optimum pipe routing and the optimum pipe diameter.

The design of the silencers meets the high demands for low noise levels in this vehicle class. Jutting out of each of the two rear silencers are two tailpipes, each of which contains an exhaust flap. The exhaust flaps are map-controlled by the DME, making it possible to achieve the sound behavior you would expect from the vehicle.

### Exhaust system of the N63 engine

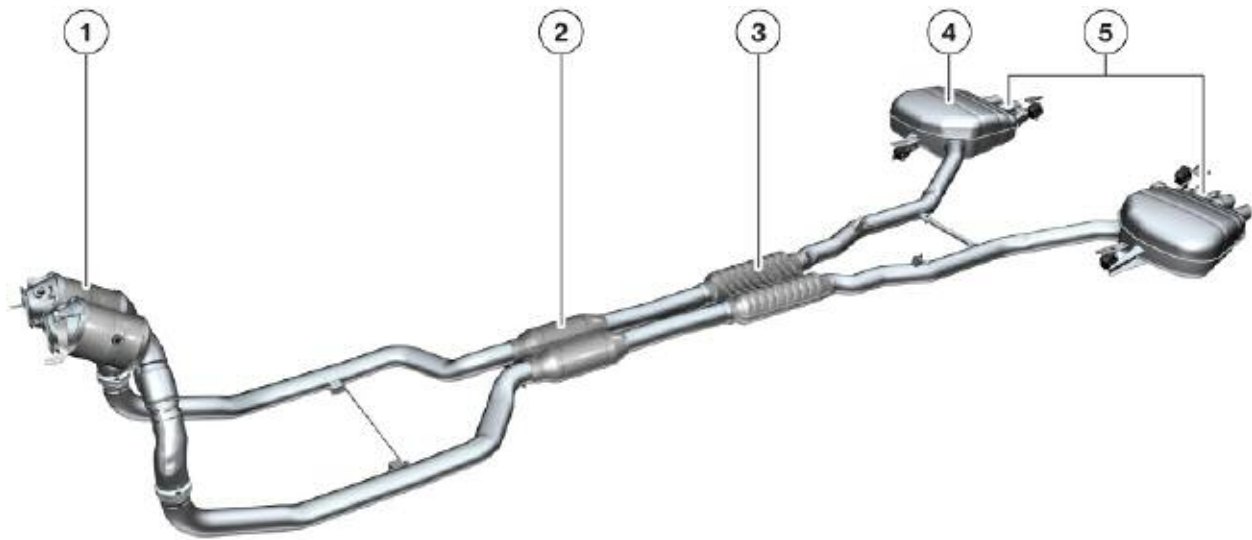

Index	Explanation	Index	Explanation
1	Catalytic converter	4	Rear silencer
2	Front silencer	5	Exhaust flaps
3	Center silencer		

With the E71, this was characterized by high load feedback, i.e. a powerful V8 sound under acceleration, settling down to a more comfortable noise level during constant speed travel. In the tuning of the F01/F02, we accomplished a V8 sound that meets the high demands for comfort in this vehicle class.

The F01/F02 fully complies with the ULEV II emission standards. Connected downstream of the turbochargers are the near-engine catalytic converters. The exhaust system is dual pipe design throughout. There are two front silencers, one center silencer and two rear silencers.

The four tailpipes project into two chrome trims integrated into the rear apron.

## Cooling System

In principle, the complex cooling system of the N63 engine is a carry-over from the E71. Nevertheless, there are a few differences:

- no separate auxiliary coolant radiator
- engine oil radiator to the front of the left-side wheel housing
- there is an additional engine oil radiator to the front of the right-side wheel housing
- liquid-cooled engine control module.

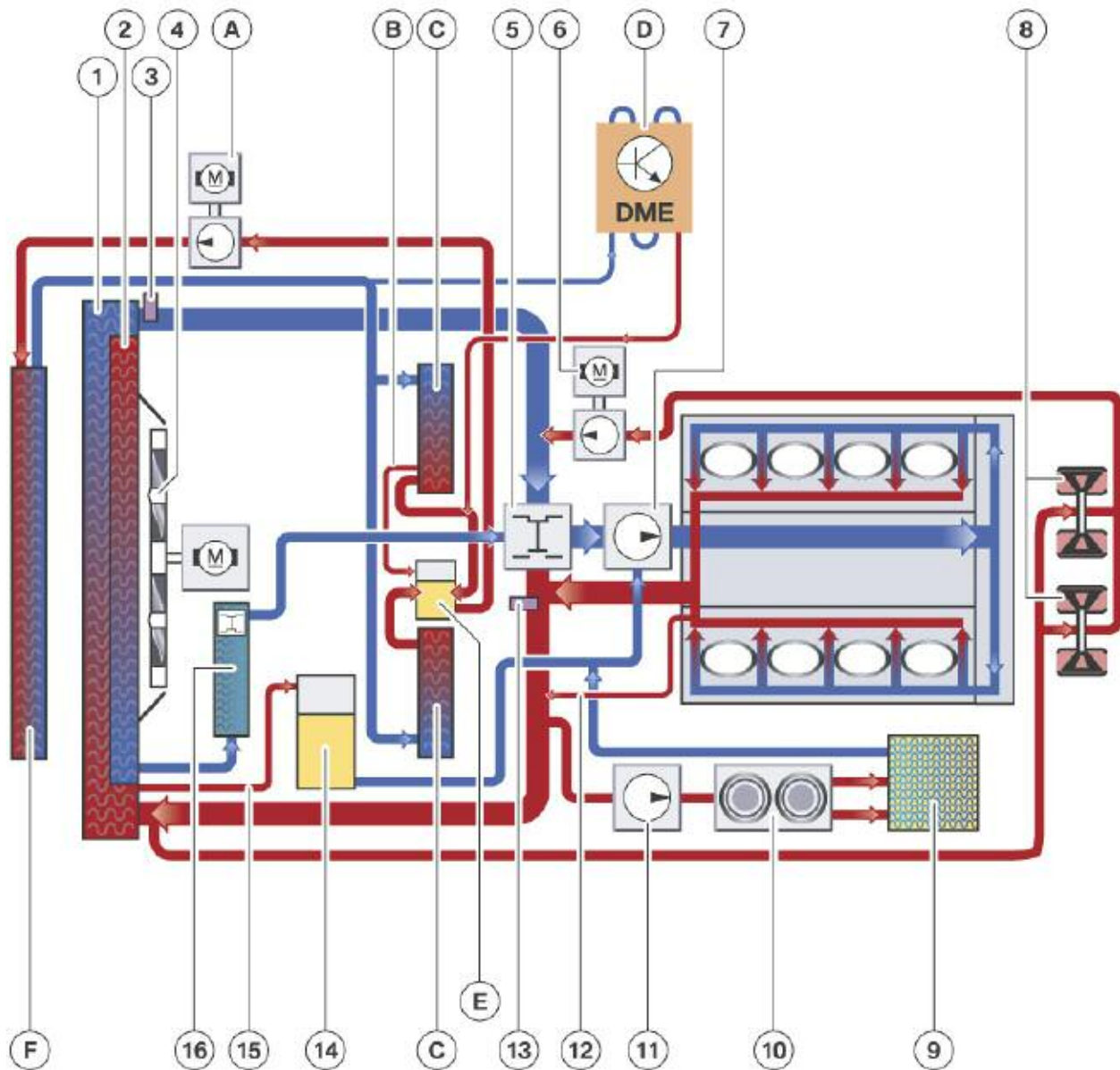

Cooling system of the N63 engine in the F01/F02

<b>Index</b>	<b>Explanation</b>	<b>Index</b>	<b>Explanation</b>
1	Radiator	12	Bleed line
2	Radiator for transmission cooling	13	Coolant temperature sensor at engine outlet
3	Coolant temperature sensor at radiator outlet	14	Expansion tank
4	Electric fan	15	Bleed line
5	Characteristic map thermostat	16	Transmission fluid-to-coolant heat exchanger
6	Electric auxiliary coolant pump for turbocharger cooling	A	Electric coolant pump for charge air cooling
7	Coolant pump	B	Bleed line
8	Exhaust turbocharger	C	Charge-air cooler
9	Heating heat exchanger	D	Digital motor electronics (DME)
10	Duo-valve	E	Expansion tank for charge air cooling
11	Electric auxiliary coolant pump for vehicle heating	F	Radiator for charge air cooling

The cooling system comprizes two separate cooling circuits as it did before. One cools the engine, one cools the charge air. For a clearer overview, the two cooling circuits are illustrated separately on the pages that follow.

## Engine Cooling

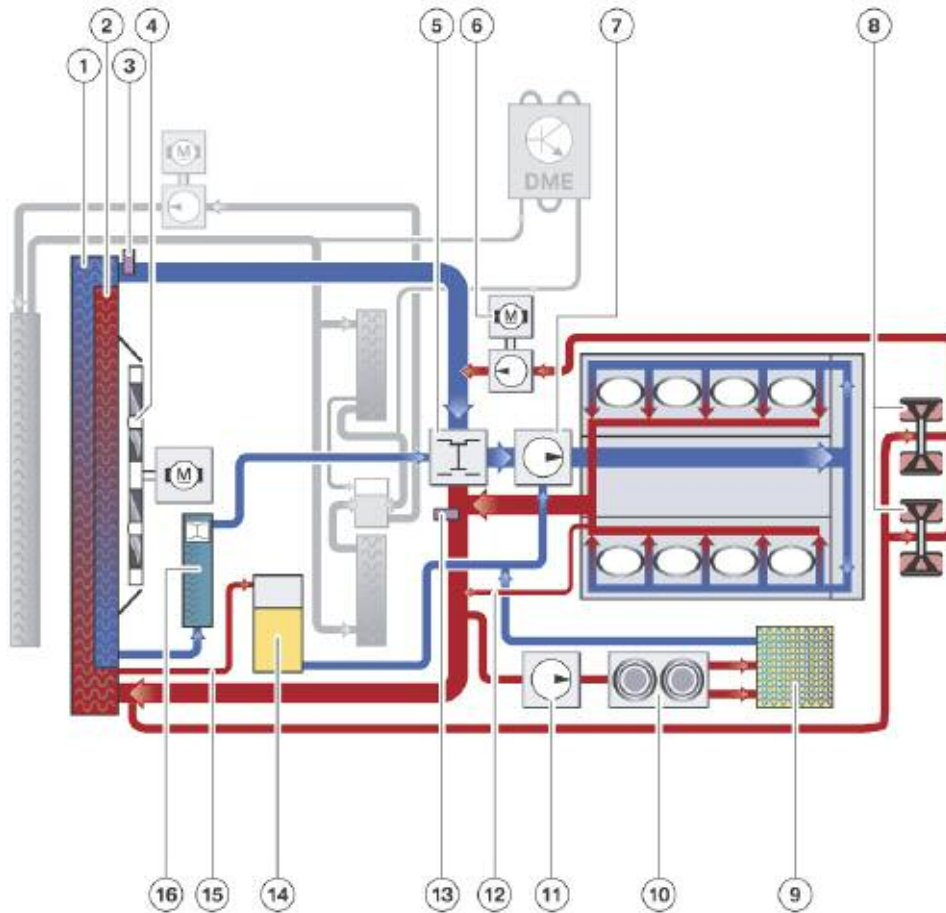

**Cooling circuit of the N63 engine in the F01/F02**

Index	Explanation	Index	Explanation
1	Radiator	9	Heating heat exchanger
2	Radiator for transmission cooling	10	Duo-valve
3	Coolant temperature sensor at radiator outlet	11	Electric auxiliary coolant pump for vehicle heating
4	Electric fan	12	Bleed line
5	Characteristic map thermostat	13	Coolant temperature sensor at engine outlet
6	Electric auxiliary coolant pump for turbocharger cooling	14	Expansion tank
7	Coolant pump	15	Bleed line
8	Exhaust turbocharger	16	Transmission fluid-to-coolant heat exchanger

---

For the most part, the layout of the N63 engine cooling circuit in the F01/F02 corresponds to that of the E71. The only obvious difference is that no auxiliary coolant radiator is used in the F01/F02. This is made possible by the use of high-performance coolant radiators. These also have a more compact height, which is essential when it comes to pedestrian safety.

As usual, the coolant radiator has an integrated low-temperature section for transmission cooling. Thanks to the on-demand control of the electric fan, the characteristic map thermostat and the electric auxiliary coolant pump, we were able to realize a thermal management system that yields benefits in terms of fuel economy, comfort and power output.

The entire cooling module and the engine oil radiator and its lines are decoupled from the body in order to optimize sound characteristics in the passenger compartment.

## Charge Air Cooling

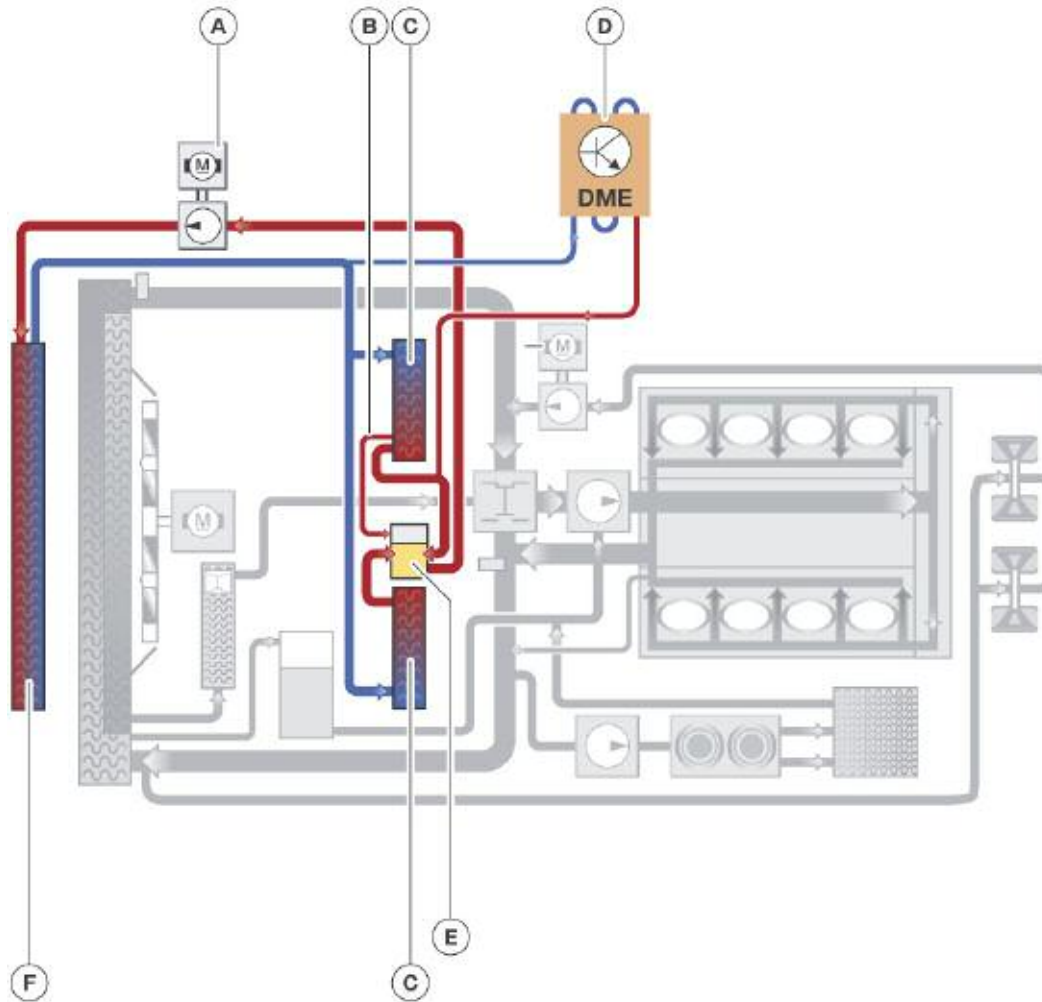

Index	Explanation	Index	Explanation
A	Electric coolant pump for charge air cooling	D	Digital motor electronics (DME)
B	Bleed line	E	Expansion tank for charge air cooling
C	Charge-air cooler	F	Radiator for charge air cooling

As it did in the E71, the turbocharged N63 engine operates with an indirect form of charge air cooling. Heat from the charge air is transferred to the coolant, then the hot coolant radiates heat into the ambient air. There is a dedicated coolant circuit for this function. In the F01/F02, the cooling for the DME is also integrated into this coolant circuit. For the first time at BMW, the engine control unit is liquid-cooled.



## Engine Electrical System

### Engine Control Unit

In the F01/F02, too, the N63 engine is controlled by the MSD85 as is the case in the E71. This control unit has been modified to make it compatible with the FlexRay used in the F01/F02.

As with the other engine variants, the control unit is located to the front of the right-side spring strut dome. By contrast with the other two engine variants, however, this control unit is liquid-cooled rather than air-cooled.

### Cooling of the engine control unit of the N63 engine



Index	Explanation	Index	Explanation
1	Sealing frame	5	Coolant line
2	Electronics box cover	6	Engine control unit
3	Coolant return	7	Electronics box
4	Coolant supply		

For this purpose, the housing of the control unit features two windings in the one coolant line, which is connected to the low temperature cooling circuit for charge air cooling.

The lower section of the electronics box is open to the outside. The upper section, which contains the connections, has a watertight seal.

# System Overview

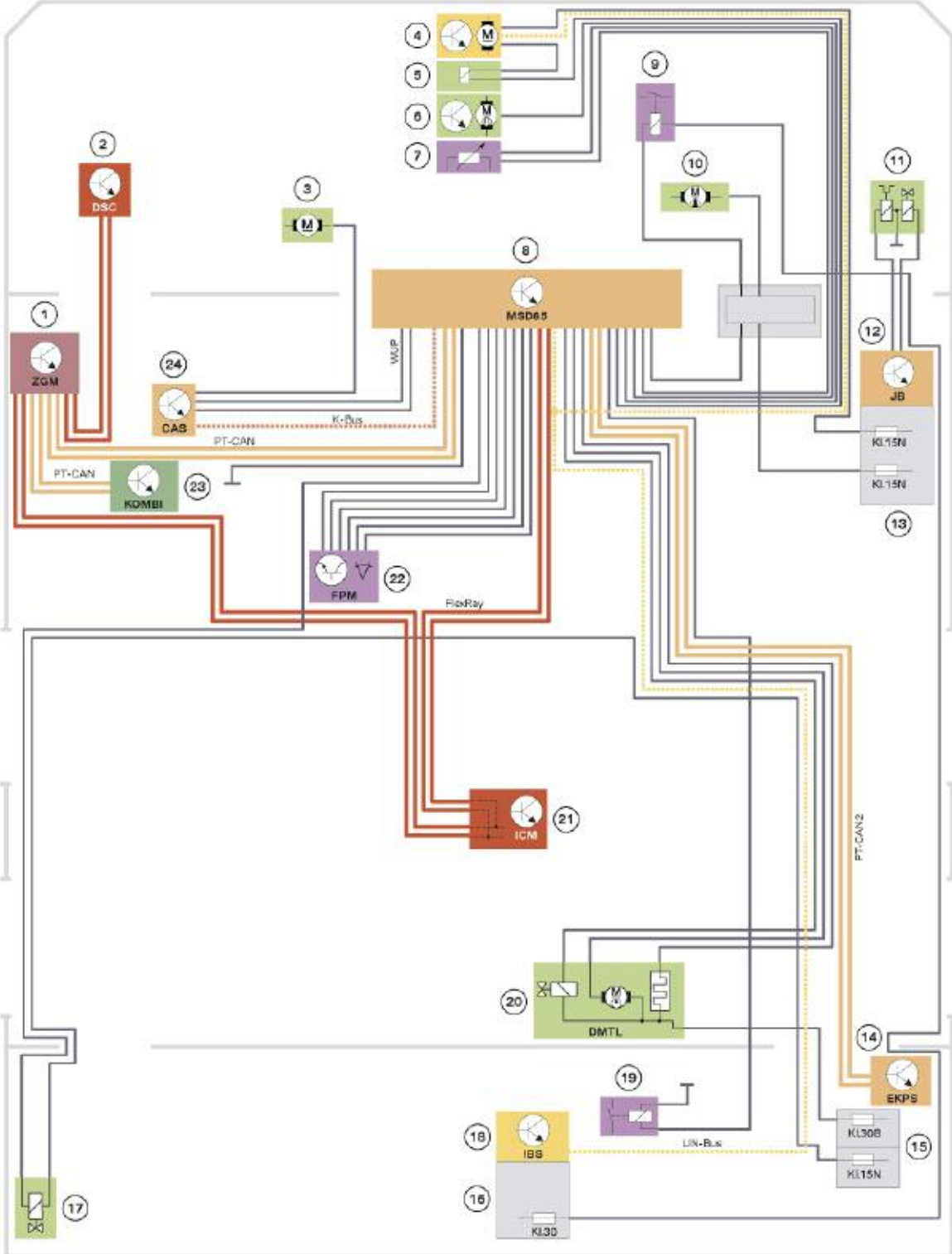

Connection of the N63 engine to the on-board network

<b>Index</b>	<b>Explanation</b>	<b>Index</b>	<b>Explanation</b>
1	Central gateway module	13	Junction box power distributor
2	Dynamic Stability Control	14	Electronic fuel pump controller
3	Starter	15	Power distributor, rear right
4	Active cooling air flaps	16	Power distributor, battery
5	Passive cooling air flaps	17	Exhaust flaps
6	Electric fan	18	Intelligent battery sensor
7	Coolant temperature sensor at radiator outlet	19	Electric fan relay
8	MSD85	20	Fuel tank leak diagnostic module
9	Electric auxiliary coolant pump for charge air cooling	21	Integrated Chassis Management
10	DME main relay	22	Accelerator pedal module
11	A/C compressor	23	Instrument cluster
12	Junction box electronics	24	Car Access System

# Fuel Supply System

Due to the nature of the installation space in the vehicle, the fuel tank is divided into two chambers. The fuel supply system has two delivery units that are accommodated in the right and left fuel tank halves.

In the event of the surge chamber being completely empty, initial fill valve (1) enables fuel to enter the surge chamber during the refueling process.

**Fuel supply system on F01/F02 with N63 engine**

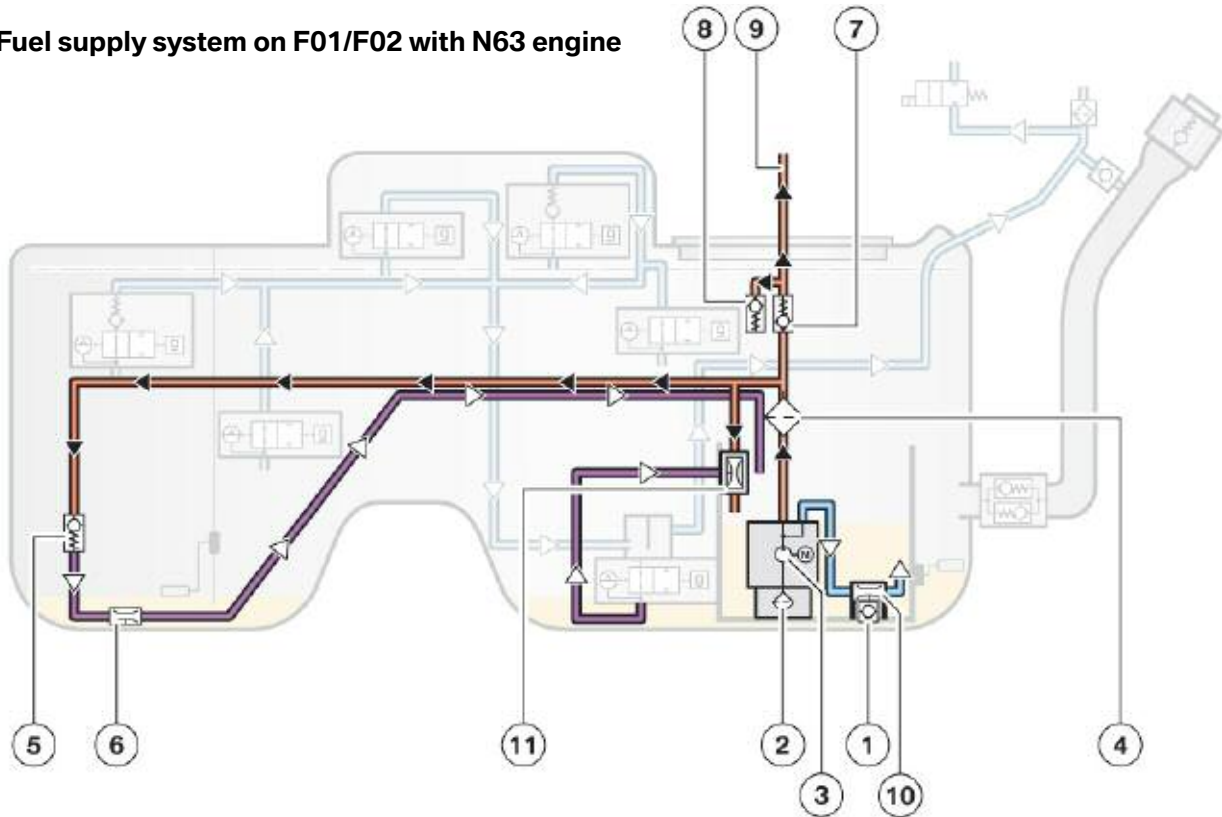

Index	Explanation	Index	Explanation
1	Initial fill valve	7	Anti-leak valve
2	Intake mesh filter	8	Pressure limiting valve
3	Fuel pump	9	Feed line
4	Fuel filter	10	Suction jet pump
5	Non-return valve	11	Suction jet pump
6	Suction jet pump		

---

NOTES

PAGE

# Fuel Supply System for the N63 Engine

## System Overview

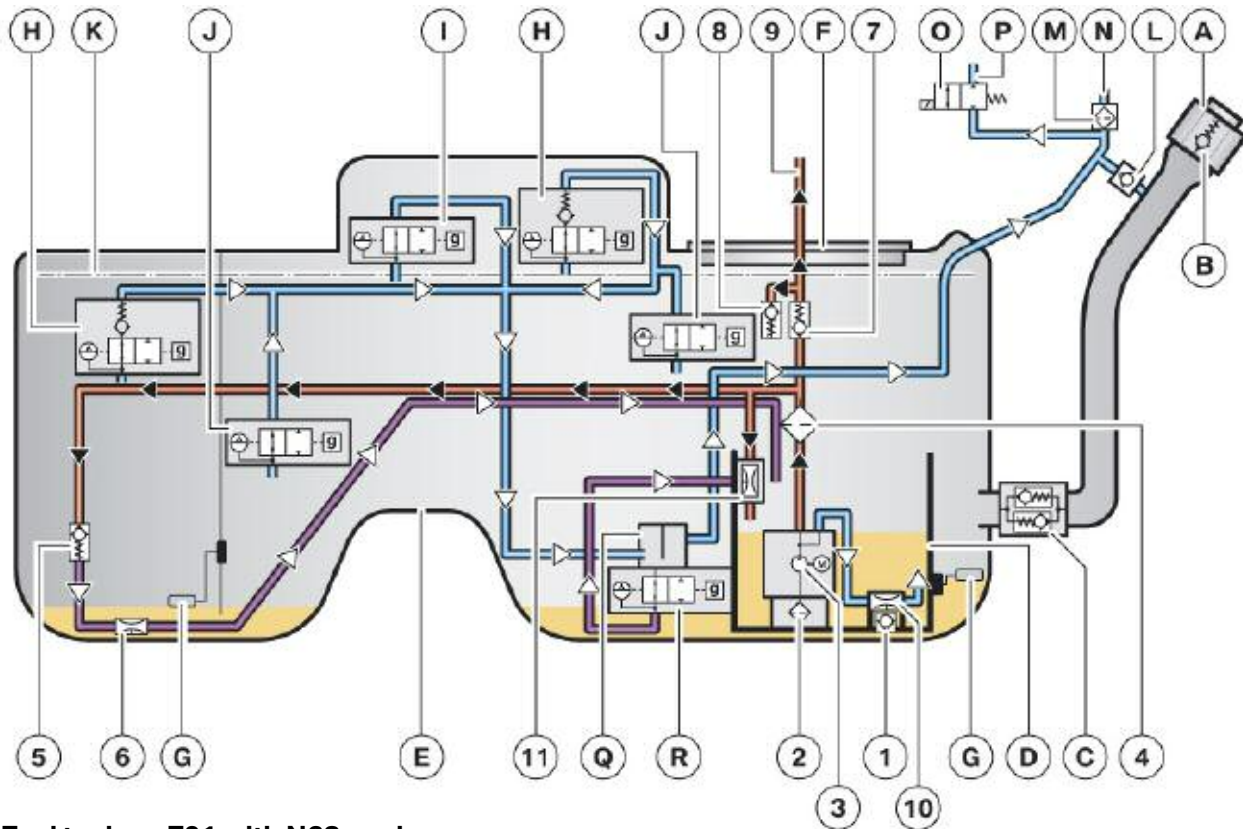

**Fuel tank on F01 with N63 engine**

Fuel passes through suction strainer (2) and enters fuel pump (3) and is then pumped to feed line (9) through fuel filter (4). The fuel pump resides in the surge chamber. A pressure limiting valve (8) is integrated into the feed line in the fuel tank.

For the first time for a gasoline engine, we are no longer using a pressure regulator. Instead, operation of the electric fuel pump is pressure-regulated. In response to the signal from the low-pressure fuel sensor, the speed of the electric fuel pump is adjusted to achieve the desired delivery pressure upstream of the high-pressure pump.

A further line branches off downstream of the fuel pump into the left half of the fuel tank and carries fuel from the left half into the surge chamber by way of a non-return valve (5) and suction jet pump (6).

Index	Explanation	Index	Explanation
A	Fuel cap	P	Purge air line
B	Pressure relief valve	Q	Fuel trap
C	Non-return flap with pressure relief valve	R	Roll-over valve
D	Surge chamber	1	Initial fill valve
E	Fuel tank	2	Intake mesh filter
F	Service cover	3	Electric fuel pump
G	Lever-type sensor	4	Fuel filter
H	Service breather valve with over fueling protection	5	Non-return valve
I	Filler breather valve	6	Suction jet pump
J	Service breather valve without over fueling protection	7	Anti-leak valve
K	Maximum fill level	8	Pressure limiting valve
L	Non-return valve	9	Feed line
M	Carbon canister (AKF)	10	Suction jet pump
N	Opening	11	Suction jet pump
O	Fuel tank vent valve (TEV)		

The non-return valve (5) prevents fuel from flowing back from the right half to the left half of the fuel tank while the engine is switched off.

When you switch off the engine, the feed line is depressurized but cannot run dry because, with the system being airtight, no air is able to enter the line. Anti-leak valve (7) prevents the fuel tank from leaking in the event of damage to the lines on the engine or underbody.

A further line en route to the left half of the fuel tank branches off to another suction jet pump (11), which sucks fuel out of the fuel trap and delivers it to the surge chamber.

Another line exits the pump carrying fuel pumped from the fuel tank to the surge chamber by suction jet pump (10).

Fuel tank overview on F01 with N63 engine

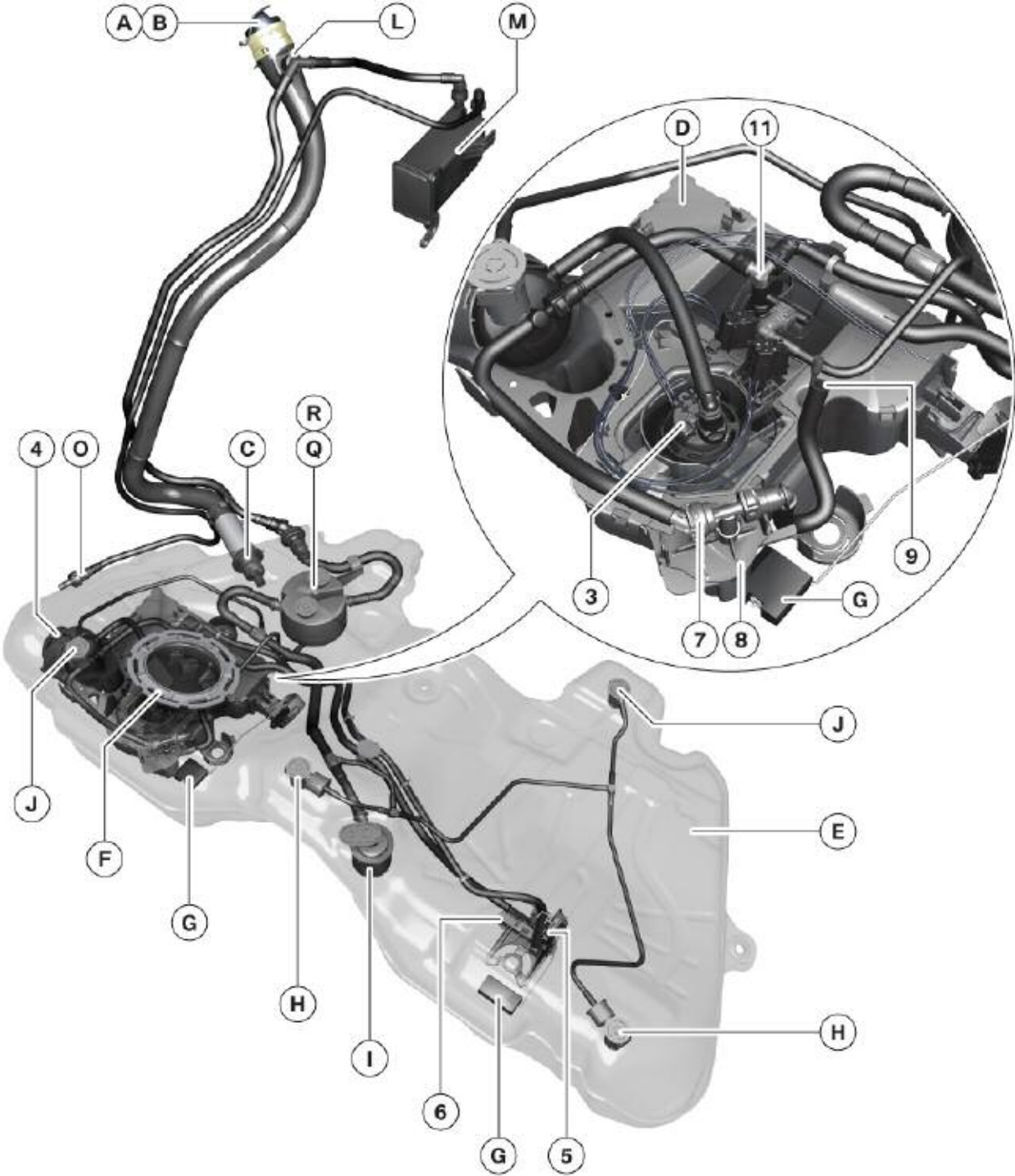



<b>Index</b>	<b>Explanation</b>	<b>Index</b>	<b>Explanation</b>
A	Fuel cap	P	Purge air line
B	Pressure relief valve	Q	Fuel trap
C	Non-return flap with pressure relief valve	R	Roll-over valve
D	Surge chamber	1	Initial fill valve
E	Fuel tank	2	Intake mesh filter
F	Service cover	3	Electric fuel pump
G	Lever-type sensor	4	Fuel filter
H	Service breather valve with over fueling protection	5	Non-return valve
I	Filler breather valve	6	Suction jet pump
J	Service breather valve without over fueling protection	7	Anti-leak valve
K	Maximum fill level	8	Pressure limiting valve
L	Non-return valve	9	Feed line
M	Carbon canister (AKF)	10	Suction jet pump
N	Opening	11	Suction jet pump
O	Fuel tank vent valve (TEV)		

## Fuel tank breather system and functions

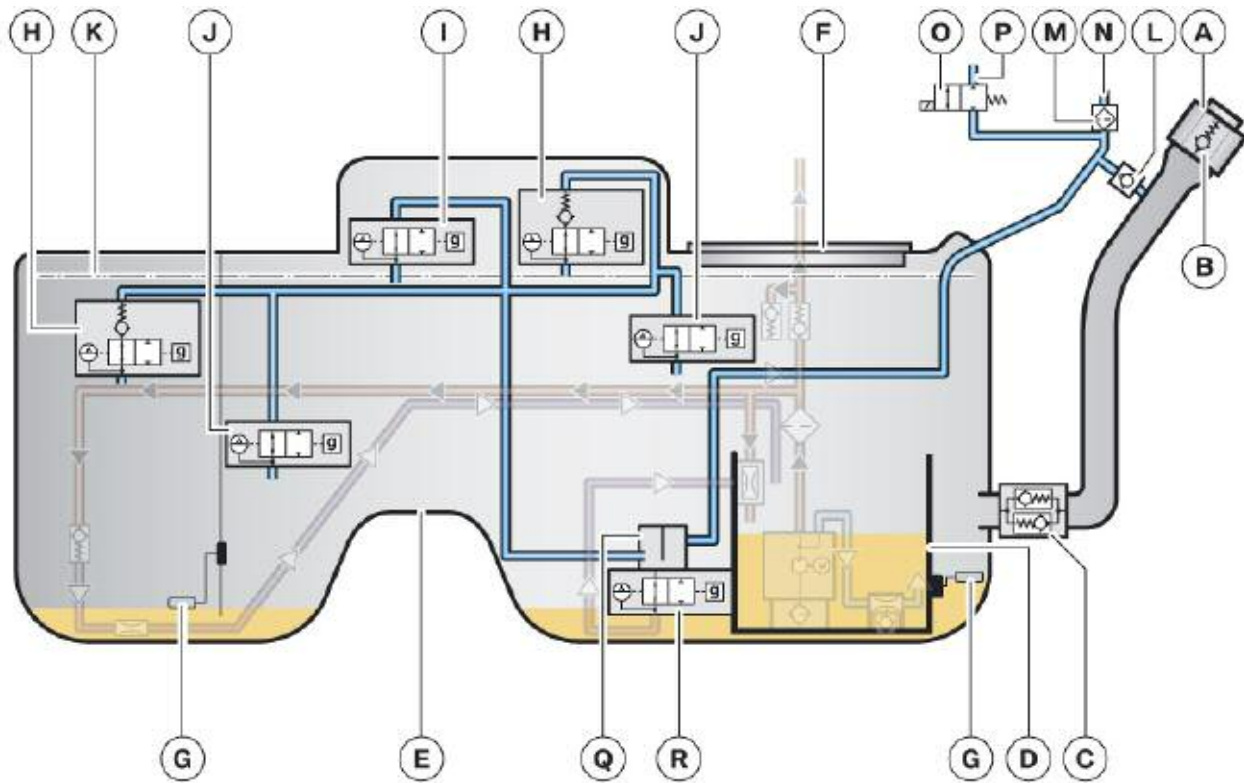

### Fuel tank breather system on F01/F02 with petrol engine

Index	Explanation	Index	Explanation
A	Fuel cap	J	Service breather valve without over fuelling protection
B	Pressure relief valve	K	Maximum fill level
C	Non-return flap with pressure relief valve	L	Non-return valve
D	Surge chamber	M	Carbon canister (AKF)
E	Fuel tank	N	Opening
F	Service cover	O	Fuel tank vent valve (TEV)
G	Lever-type sensor	P	Purge air line
H	Service breather valve with over fuelling protection	Q	Fuel trap
I	Filler breather valve	R	Roll-over valve

---

Fuel filler cap (A) has an integral pressure relief valve (B) to protect fuel tank (E) from excess pressure. At the end of the fuel filler neck, there is a non-return flap with a pressure relief valve (C). The non-return flap prevents fuel from sloshing back into the fuel filler neck. The non-return flap is sealed closed by a spring. In the event of a build-up of pressure in the fuel tank, the pressure relief valve in the non-return flap ensures that the excess pressure can escape through the fuel filler pipe and out of the fuel filler cap through the pressure relief valve.

The components in the fuel tank are accessible through the service cover (F). The fuel level is detected by the two lever-type sensors (G).

The surge chamber (D) ensures that the fuel pump never pumps dry. The surge chamber is permanently connected to the fuel tank and cannot be replaced separately.

The F01/F02 has a whole range of breather valves in the fuel tank. In principle, all of these valves fulfil the breather function, both during vehicle operation and during refueling.

Despite this, they are named to reflect their main purpose. They are therefore divided into filler valves and service breather valves. The service breather valves have a smaller opening, which means that, during refueling, they alone would not be able to let air escape from the fuel tank fast enough. There are service breather valves with and without over fueling protection.

The service breather valves are arranged in such a way that air can still be released even if the vehicle is parked up on one side.

The filler breather valve is located at a high position. If the fuel level rises to this height during refueling, the valve closes. Air can no longer escape from the fuel tank fast enough, which causes fuel to rise up the filler pipe and switch off the fuel nozzle.

To enable the release of air to continue, there is a service breather valve located at the highest point. However, the presence of the valve in this location means that the fuel tank could be overfilled in the event of persistent refueling. Consequently, fuel would enter the activated charcoal filter and ultimately flow back out of the opening. To prevent this, the highest service breather valve is equipped with over fueling protection like the one on the left-hand side of the vehicle (as a safeguard if the vehicle were parked up on one side).

Fuel that is carried along with the release of air is collected in a fuel trap and pumped back into the surge chamber.

## Non-return Flap

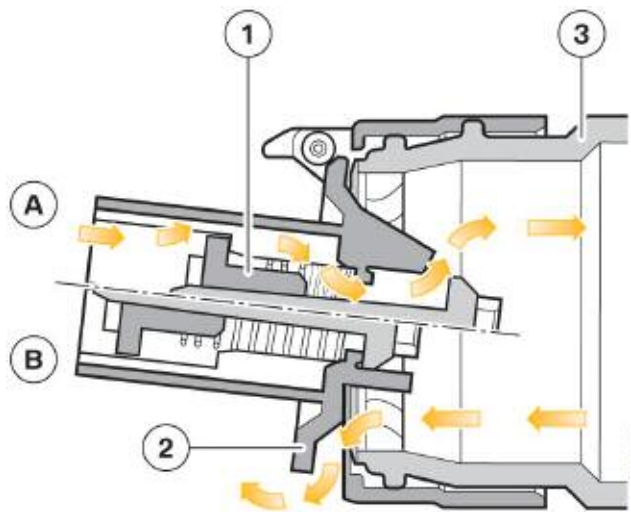

Index	Explanation
A	Pressure relief valve open
B	Pressure relief valve closed
1	Pressure relief valve
2	Non-return flap
3	Fuel filler pipe

The non-return flap forms a tight seal. A force of approximately 0.15 N is required to open the non-return flap. This force is slightly exceeded during any type of refueling.

The non-return flap on the F01 is equipped with a pressure relief valve. The purpose of this pressure relief valve is to prevent excessive pressures from building up in the fuel tank. If the pressure in the fuel tank rises to over 150 mbar, the pressure relief valve opens and the pressure is able to escape through the fuel filler pipe and the breather line/pressure relief valve in the fuel cap.

The pressure relief valve in the non-return flap on the F01 is a new concept because the breather line is not protected by the body along its entire length. In the event of an accident, therefore, the breather line could be squeezed closed.

## Filler Breather Valve

The filler breather valve has several functions. As the name suggests, the valve fulfills the filler-neck breather function. In addition, however, it also performs the service breather function. It also has a rollover function.

The filler breather valve is notable for its large opening, which allows air to escape rapidly from the tank during refueling. If, during refueling, the float of the filler breather valve ascends with the rising fuel level and thereby closes the breather hole, fuel will rise up the fuel filler pipe and switch off the fuel nozzle.

During vehicle operation, the pressure in the fuel system can rise as a result of the increase in temperature. This pressure is allowed to escape through the filler and service breather valve and the fuel trap. Fuel that is carried along in the process is collected in the fuel trap and sucked back while the fuel pump is in operation.

### Filler breather valve

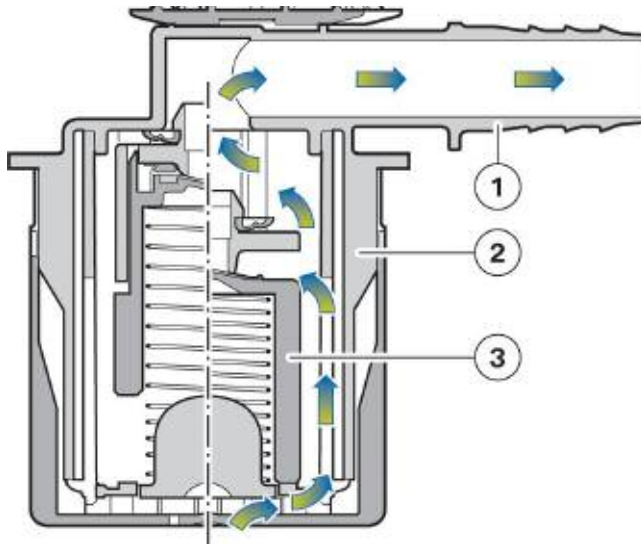

Index	Explanation
1	Connection to fuel trap
2	Breather connection
3	Casing

### Service breather valve with over fueling protection

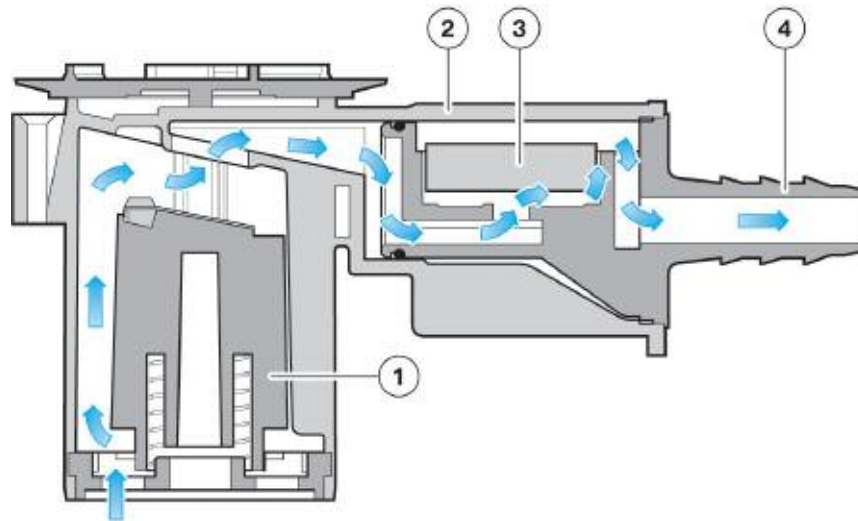

Index	Explanation	Index	Explanation
1	Float/roll-over valve	3	Plate
2	Casing	4	Connection to fuel trap

The service breather valve with over fueling protection is responsible for the release of air during vehicle operation. It also has a roll-over function.

A feature worth noting is the integrated over fueling protection. The service breather valve with over fueling protection is fitted with a plate that seals the breather hole under its own weight. During refueling, this plate is lifted by the build-up of excess pressure in the fuel tank and the resultant flow of air, and the filler breather valve is then able to fulfil the purpose for which it was designed.

If the float of the filler breather valve now ascends with the rising fuel level and thereby closes the breather hole, fuel will rise up the fuel filler pipe and switch off the fuel nozzle.

As soon as the fuel in the tank settles down, the fuel level drops slightly and the float no longer obstructs the filler breather hole. It would now be possible to refuel a little more. This refueling needs to be prevented, which is where the plate plays its part. As refueling involves only a low volumetric flow of fuel, the plate's opening pressure is not reached, so no air can escape, the fuel level in the fuel filler pipe rises again and the fuel nozzle switches off again.

During vehicle operation, the pressure in the fuel system can rise as a result of the increase in temperature. If the pressure in the complete fuel tank (fuel level above service breather valves) rises approximately 55 mbar above atmospheric pressure, the plate is lifted and the pressure can escape through the fuel trap. Fuel that is carried along in the process is collected in the fuel trap and sucked back while the fuel pump is in operation.

In this way, air can still be released even if the fuel tank is full with no risk of over fueling.

### Service breather valve without over fueling protection

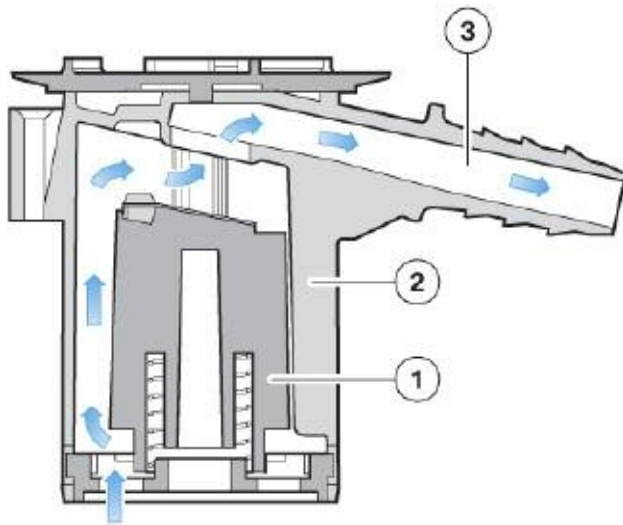

Index	Explanation
1	Float/roll-over valve
2	Casing
3	Connection to fuel trap

The service breather valve without over fueling protection is responsible for the release of air during vehicle operation. It also has a roll-over function.

The service breather valve without over fueling protection also makes it possible for air to enter the fuel tank.

During refueling, the rising fuel level lifts the float of the filler breather valve, which seals the breather hole. The fuel nozzle does not switch off, however, because there are other breather valves located higher up the fuel tank.

## Fuel Trap

With the fuel tank full, the fuel trap is located below the fuel level. The service breather valve and filler breather valve may inevitably allow some fuel to enter the fuel tank breather system. This fuel is captured by the fuel trap at the lowermost point of the fuel tank breather system. From here, it is sucked up by a suction jet pump fitted near the fuel pump and pumped back into the surge chamber. As a result, no air is able to leak out of the vehicle, even if the vehicle were to overturn.

A float in the fuel trap prevents fuel from entering the liquid trap through the return line when the fuel level is high. The float is designed to also act like a roll-over valve, sealing the fuel tank from the breather line in the event of the vehicle overturning.

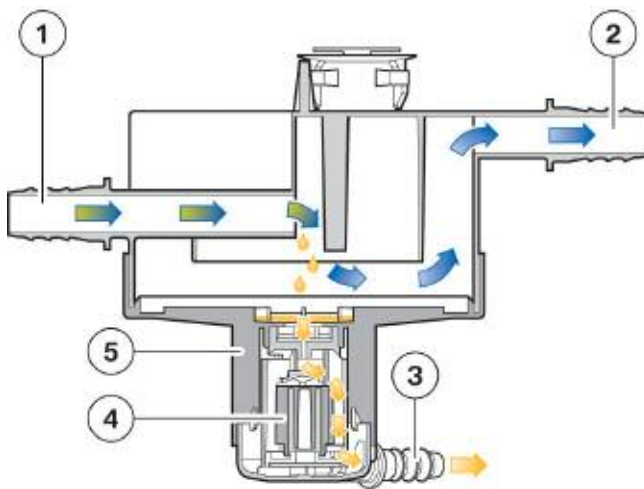

Index	Explanation
1	Connection to breather valves
2	Breather connection
3	Suction jet pump connection
4	Float (roll-over valve)
5	Casing

## Fuel Pump

The electric fuel pump (EKP) is controlled by the EKP control unit by means of a PWM signal. The EKP control unit in turns receives a request from the ECM (DME).

This request used to be based on load and engine speed. Now the regulation is pressure-sensitive. For this purpose, a fuel pressure sensor is fitted to the fuel line directly upstream of the high-pressure pump.

This allows the electric fuel pump to be controlled on demand. This reduces the energy consumption of the fuel pump, which improves fuel economy.

### Pressure Limiting Valve

The pressure limiting valve is connected to ground by the plug-in contacts on the service cover. This prevents electrostatic charge on the valve.

The pressure limiting valve keeps fuel pressures in the feed section lower than to a maximum of 5.8 bar (approximate).

This prevents excess pressures from building up in the feed line. Excess pressures would otherwise occur if the fuel filter were to become blocked, which would place the feed section of the fuel system under unnecessarily heavy loads.

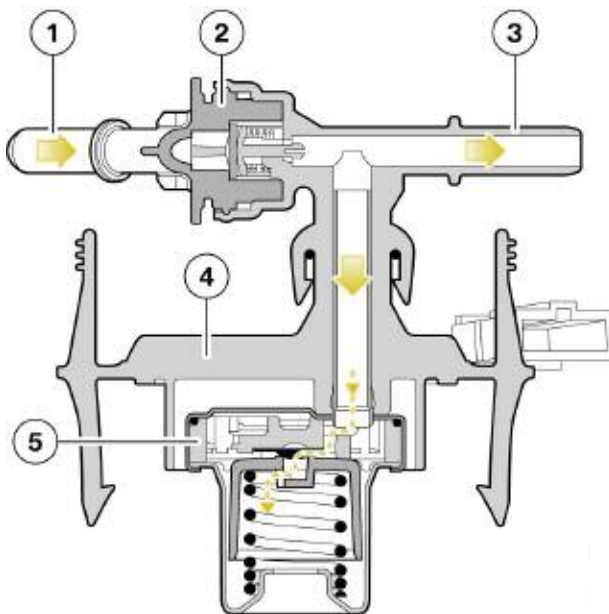

Index	Explanation
1	Connection from electric fuel pump
2	Anti-leak valve
3	Connection to fuel filter
4	Casing
5	Pressure limiting valve

**Pressure limiting and anti-leak valve**



# Fuel Supply and Control Schematic Overview

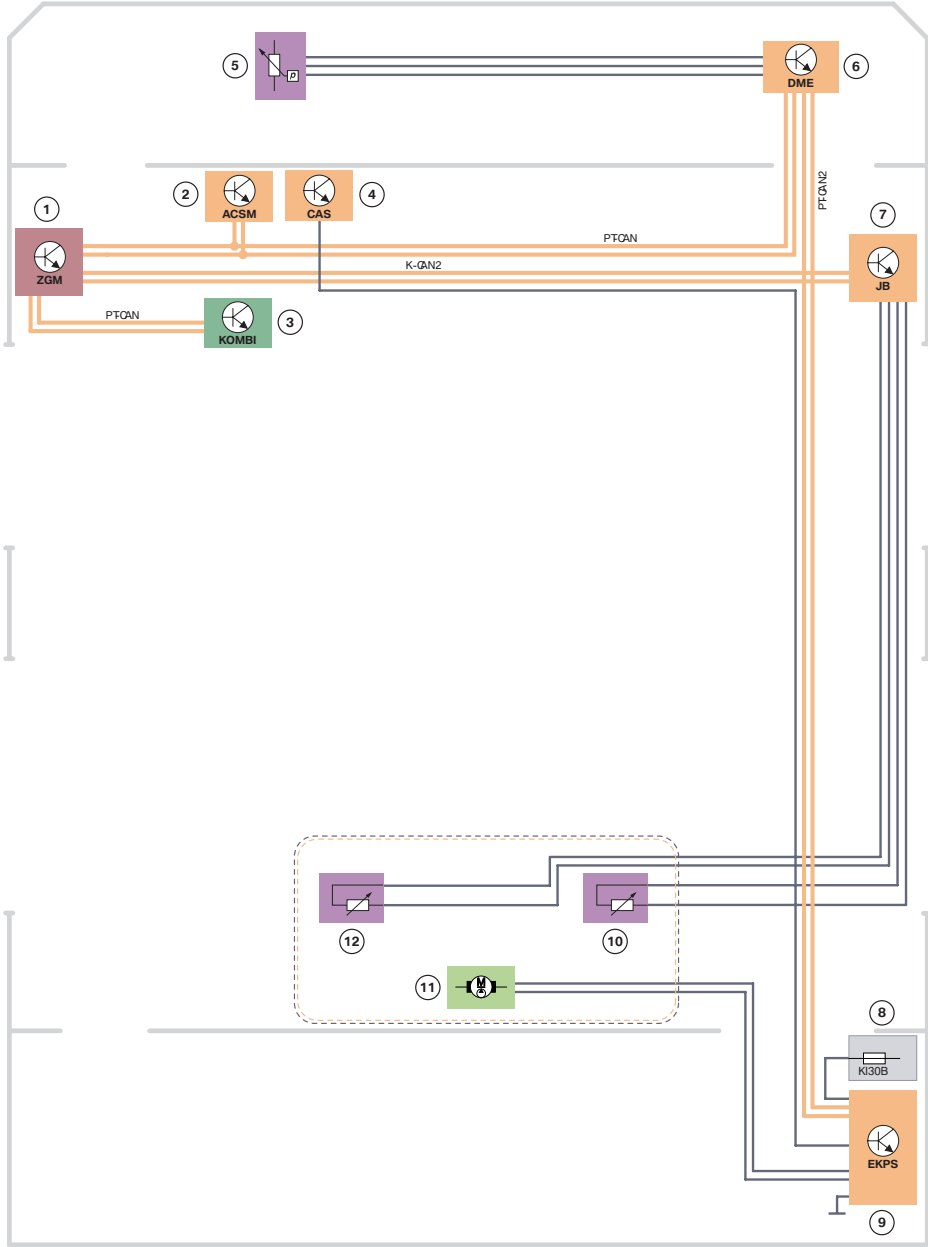

Index	Explanation	Index	Explanation
1	Central Gateway Module	7	Junction Box Electronics
2	Advanced Crash Safety Module	8	Power distribution box, right rear
3	Instrument Cluster	9	Electric Fuel Pump Module
4	Car Access System	10	Fuel level sensor, right
5	Fuel pressure sensor	11	Electric fuel pump
6	Engine Control Module (DME)	12	Fuel level sensor, left

## Automatic Transmission

The F01/F02 is available exclusively with an automatic transmission. The transmission is GA6HP26TU that was introduced with the E70 and was subsequently fitted in many model series since.

### GA6HP26TU



The basic transmission (GA6HP26) was introduced with the E65/E66. Even then, they featured an electronic gearshift. The F01/F02 has an electronic gearshift as well, but the gear selector switch has been relocated to the center console, as it is in the E70/E71 or E60/E61 LCI.

## Technical Data

	<b>750i/Li</b>
Gearbox	GA6HP26TU
Transmission type	Automobile automatic transmission with six forward gears and one reverse gear in standard arrangement.
Transmission capacity in kW	300
Transmission capacity in Nm	650
Torque converter	ZDW260
Maximum permissible constant speed of the torque converter in rpm	7000
<b>Transmission gear ratio</b>	
• 1st gear	4.171
• 2nd gear	2.340
• 3rd gear	1.521
• 4th gear	1.143
• 5th gear	0.867
• 6th gear	0.691
• Reverse gear	3.403
Transmission weight including oil in kg	92.4
Control	Electrohydraulic with electronic gearshift control
Towing capability	500 km at up to 80 km/h
Maximum uphill/downhill gradient during a journey	50 %
Maximum gradient from a standing start (forwards/reverse)	32 %

# Transmission Control Schematic Overview

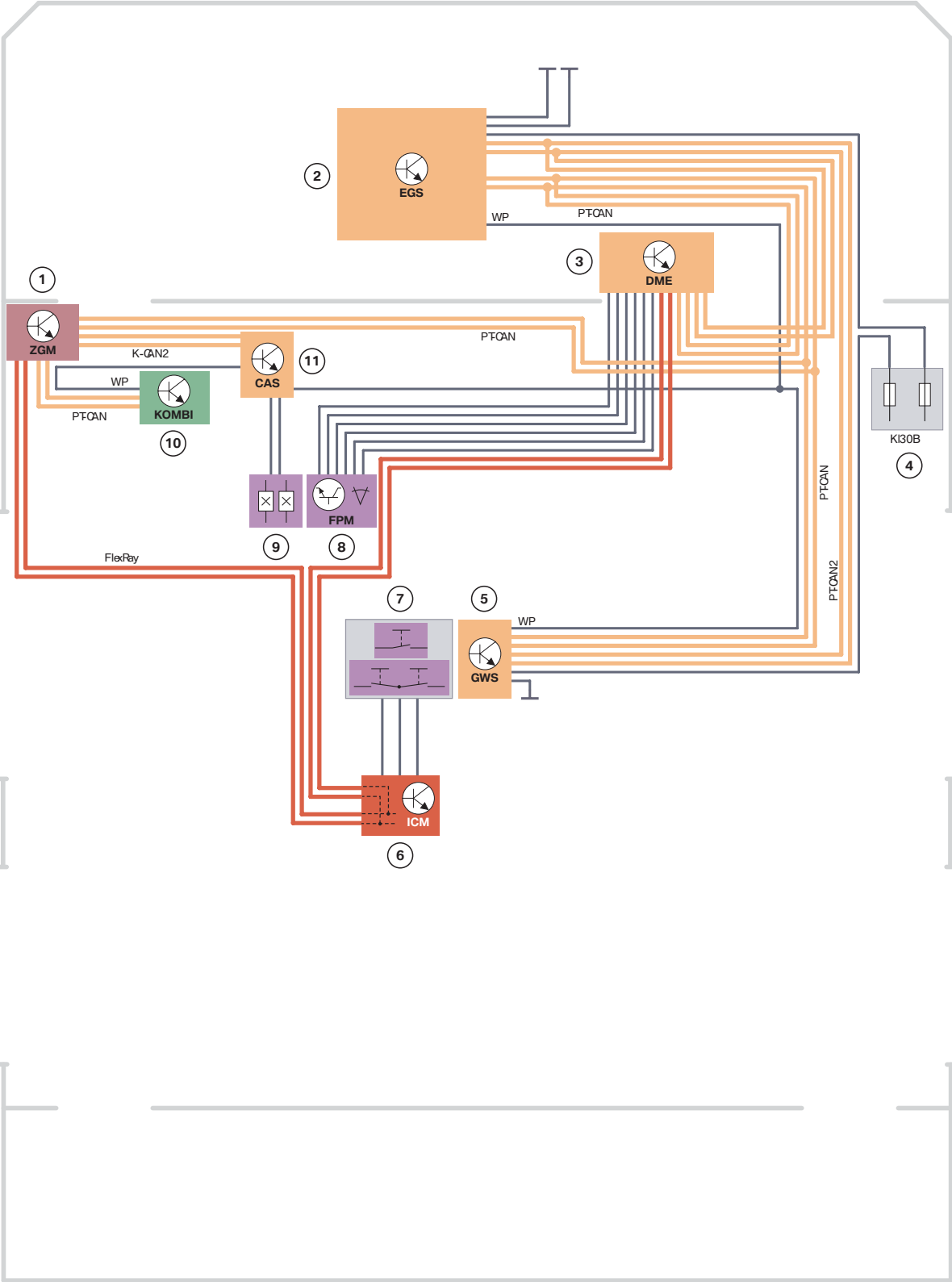

Index	Explanation	Index	Explanation
1	Central gateway module	7	Dynamic driving switch and DSC button
2	Electronic gearshift control	8	Accelerator pedal module
3	Engine control unit	9	Brake light switch
4	Junction box power distributor	10	Instrument cluster
5	Gear selector switch	11	Car Access System
6	Integrated Chassis Management		

## Gear Selector Switch

The gear selector switch on the F01/F02 has been carried over from the E6x and E7x. In both automatic and manual mode, operation of the switch is monostable. In other words, the selector lever always returns to its original position.

The gear selector switch also contains the control unit (GWS), which is connected to the electric gearshift controller by the PT-CAN like it was before. The second, redundant connection, however, is no longer connected by the LIN bus as used to be the case, but by the new PT-CAN 2.



**Emergency release of the F01/F02 automatic transmission**

### Emergency Release

As you would expect, the F01/F02 has an emergency release for the automatic transmission. This functions in much the same way as that of the E70. The emergency release is located under the ashtray to the front of the gear selector switch.

## Rear Axle Differential

The key aim in the development of the final drive in the F01/F02 was to make considerable savings on weight at the same time as increasing the maximum torque transmission capacity.

In addition, efficiency was further improved by efforts to achieve optimum spline geometries. The result is a new generation of final drives, which are also notable for their new aluminum casing. These differentials are recognizable by the letters “AL” in their designation (A = aluminum casing, L = low-friction).

The new differential in the F01/02 is designated “225 AL” and weighs approximately 29.7 kilograms (approximately 65 lbs.)

Thanks to cutting edge development methods, a differential casing was made of aluminum for the first time. This has helped to achieve a weight reduction of approximately 15 % compared with previous differentials.

To satisfy the high demand for low noise levels in this vehicle class, a comprehensive range of decoupling measures were required on the vehicle. Through the use of efficient bearings, optimum spline geometries in the oil circuit and an optimum oil volume in the differential, it was possible to reduce friction losses and churning losses and to thereby increase efficiency even further. Together with better heat dissipation, this has contributed to lower oil temperatures.

## Driveshafts and Axles Shafts

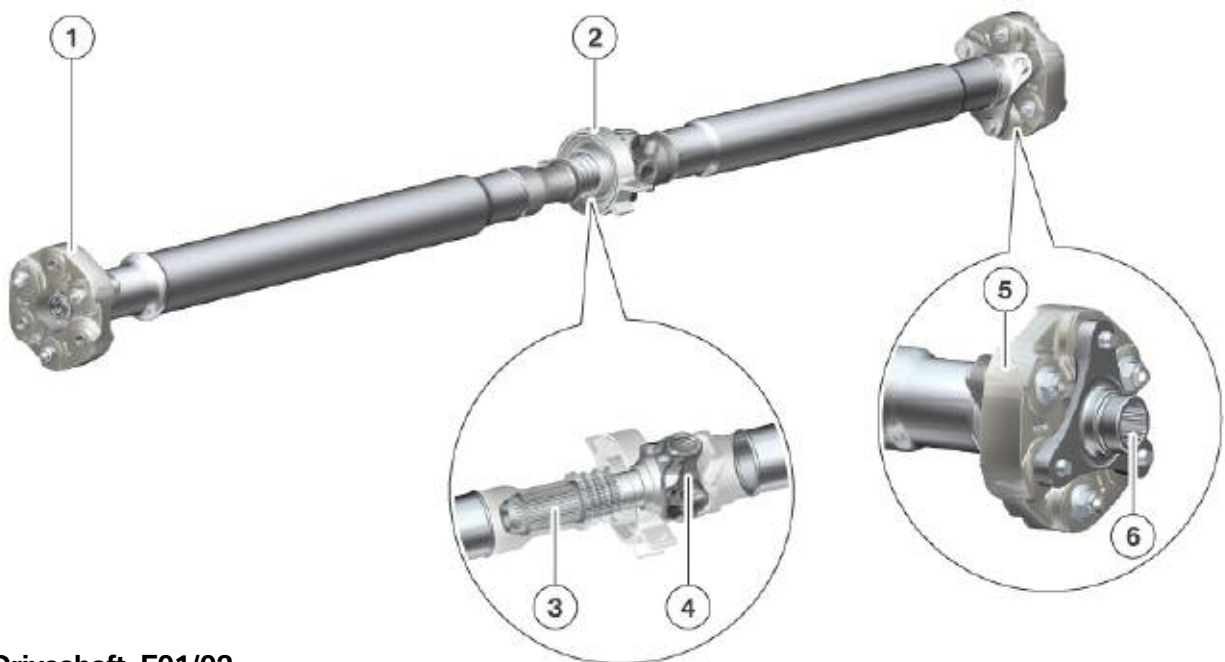

**Driveshaft, F01/02**

Index	Explanation	Index	Explanation
1	Flexible coupling on automatic transmission	4	Universal joint
2	Center connection	5	Flexible coupling on rear axle differential
3	Slide-piece connection	6	Push-fit connection

## Driveshaft

For the F01/02 the driveshaft is made from steel and designed meet the higher torque requirements.

In addition to torque transfer, key aims in the designing of the driveshaft for the F01/ F02 were to satisfy demands for comfort in terms of noise and vibration.

The joints, shaft junctions and shaft diameters were designed in such a way that no disturbance noise or vibrations at the connecting points are transmitted through the body.

On the F01/F02, the driveshaft is connected to the automatic transmission and rear axle differential exclusively by flexible couplings. This minimizes high-frequency gear teeth noise at the rear axle differential.

The connection to the automatic transmission is a screw-fitted one. At the rear axle differential end, it is push-fitted as it is on the E70. However, this is the first time that a push-fit connection with flexible coupling has been used. The center connection is a slide piece connection with universal joint.

The driveshaft absorbs some of the impact energy in the event of a head-on collision. Improvements have been made to the properties of this crash function, which is integrated into the forward driveshaft tube. The compression force under which the forward driveshaft tube is meant to deform has been further reduced with no effect on torque transfer capability.

Despite increased demands in terms of torque and comfort, it was possible to reduce weight by comparison with the predecessor model.

## Axle Shafts

The F01/F02 has axle shafts that are push-fit at each end, i.e. wheel end and differential end. The axle shafts for the N63 engine on the F01 are solid.

The journal at the rear axle differential end depends on the size of the rear axle differential. The journal at the wheel hub end comes in only the one size.

Due to the position of the rear axle differential, the drive shafts on the left and right have a different overall length.